

OWNER'S MANUAL

MIRACOOOL™ GLASS DOOR MERCHANDISER

2000L

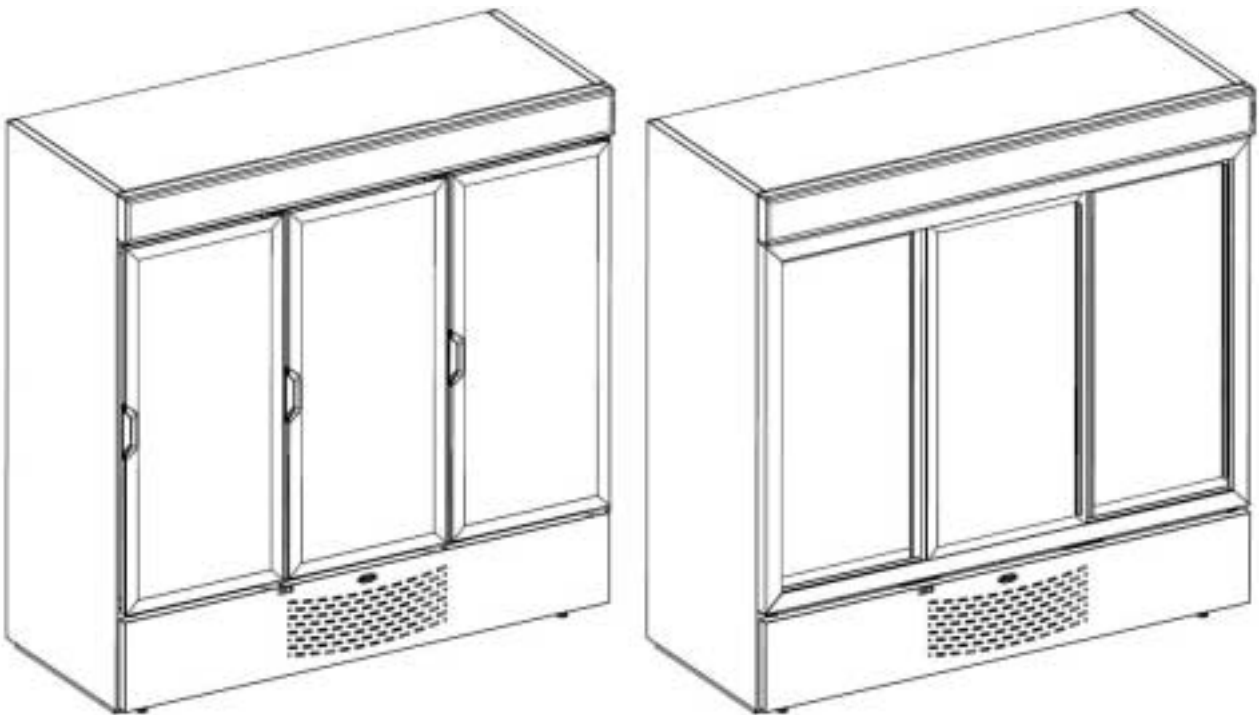

Sales Office:

P.O. Box 5932

Spartanburg, S.C. 29304-5932

Technical Service: 1-800-558-7627

Parts Order Fax: 1-800-262-9381

Manufacturer reserves the right to discontinue, or change at any time, specifications or designs without notice and without incurring obligations.

CONTENTS

	Page
GENERAL	2
UNIT INSPECTION	2
INSTALLATION	2-5
LOCATE UNIT.....	2
LEVEL	4
INSTALL SHELVES	5
CONDENSATE DISPOSAL	5
START-UP	6-7
PRELIMINARY CHECKS.....	6
INITIAL START-UP.....	7
REFRIGERATION SYSTEM SERVICE	8-11
COMPONENTS.....	8
SERVICE AND TROUBLESHOOTING	8-11
MAINTENANCE	12-13
LAMP REPLACEMENT	12
CONDENSATE REMOVAL.....	12
CONDENSER/EVAPORATOR	12
CABINET EXTERIOR.....	12
INTERIOR SURFACE.....	12

GENERAL

These instructions cover the installation, operation, and maintenance of Carrier Miracool™ series glass door merchandiser units, size 2000L.

UNIT INSPECTION

Examine all packages for damage to packaging material. Damage to external packaging may have resulted in unit damage. Check packages for all accessories and components, including legs, casters, and shelves. File a claim immediately with the shipping company if shipment is damaged or incomplete.

INSTALLATION

LOCATE UNIT

Refer to Figure 1 for unit components. Units are designed for indoor placement only. Provide at least 3 inches of space between unit cabinet and any adjacent wall or fixture.

Remove skid base by removing the retaining screws (8 hex head bolt screws). Refer to Figure 2 to remove the front grille and gain access to skid retaining screws. If optional casters will be used, unit must be located on flat, level surface. Refer to Table 1 for a list of standard parts.

TABLE 1 – STANDARD PARTS

PART	FACTORY INSTALLED	FIELD INSTALLED	QUANTITY
Shelves		X	15
Shelf Clips		X	60
Instruction Manual	-	-	1
Leveling Feet	X		4
Lamps	X		4

Note: Parts shown are for standard units. Quantity of shelves and clips may vary based on factory-supplied options.



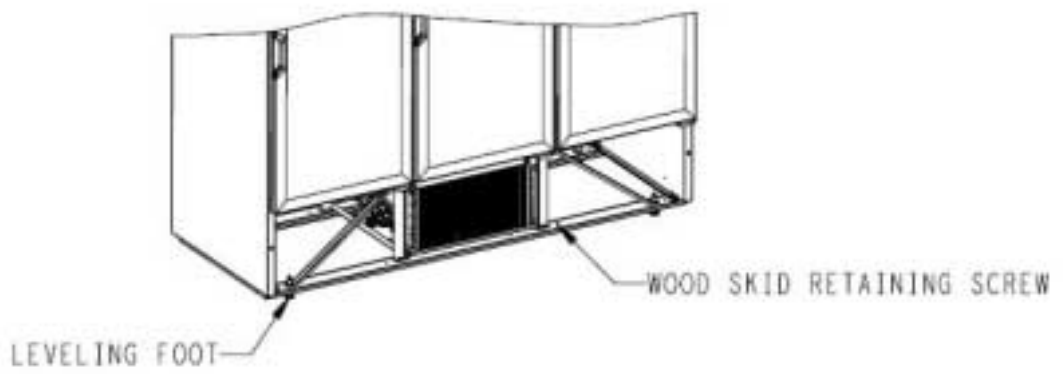
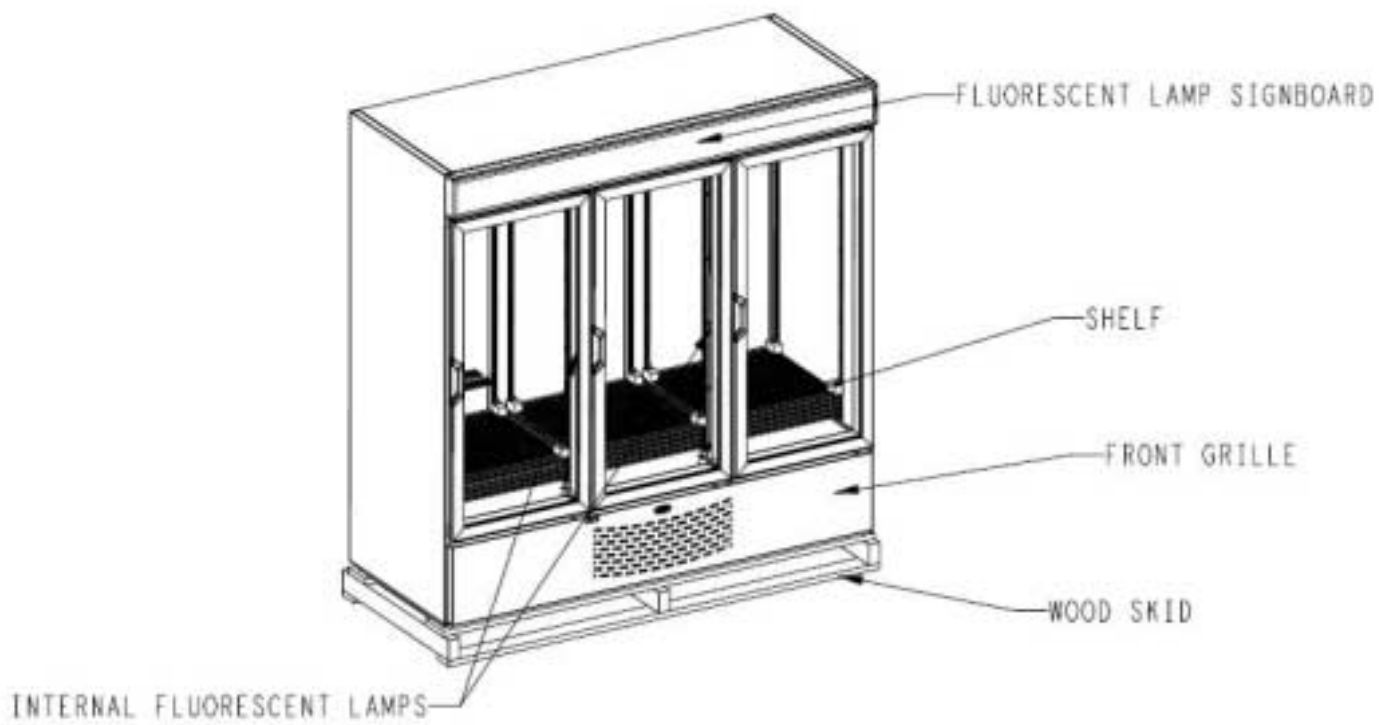

UNIT WITH FRONT GRILLE REMOVED

FIGURE 1 - MIRACOOOL™ BOTTLE COOLER UNIT COMPONENTS (MC2000H SHOWN)

LEVEL UNIT

To provide adequate condensate drainage and proper door alignment and operation of unit, the unit cabinet must be level. Leveling feet are factory installed. Remove the front grille to gain access to front and back feet.

■ TO GAIN ACCESS TO LEVELING FEET

⚠ DANGER

Before servicing unit, disconnect electrical service. Failure to disconnect electrical service could result in electrical shock and cause personal injury or death.

1. After disconnecting the unit from the power supply, remove the grille retaining screw located in the upper-most part of the grille. (See Figure 2)
2. Lift the grille up and away from the unit.
3. Unplug the power supply cord located at the bottom of the cabinet. (See Figure 3)

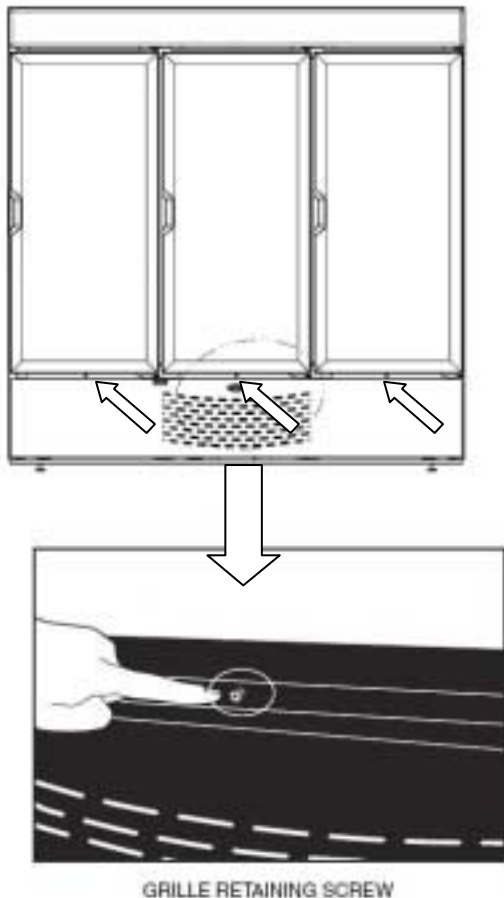

FIGURE 2 – REMOVE FRONT GRILLE

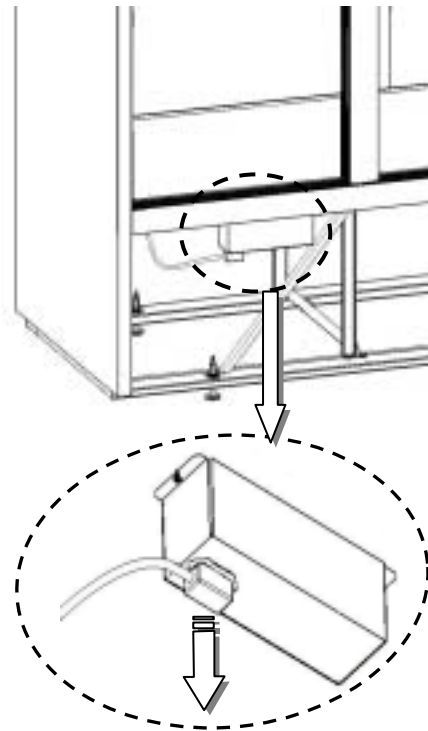

FIGURE 3 – DISCONNECT SERVICE CORD

■ TO LEVEL UNIT

⚠ DANGER

Before servicing unit, disconnect electrical service. Failure to disconnect electrical service could result in electrical shock and cause personal injury or death.

Swing Doors- The door is equipped with gravity assisted cams and will not function properly without proper leveling of cabinet. Adjust feet using adjustable wrench so that unit sits approximately level to floor and doors close properly. For best door operation, adjust leveling feet so that cabinet has a 1/16-in. rake or slant from front to back. Optional casters are available to replace leveling feet.

Sliding Doors- The door will not function properly without proper leveling of cabinet. Adjust feet using adjustable wrench so that unit sits approximately level to floor and doors close properly.

NOTE: If casters are not used, local codes may require cabinet to be sealed around the perimeter of the cabinet base. Consult local sanitation codes. Use only sealant material approved for this use, such as Dow Corning #732.

INSTALL SHELVES

Product shelves and a bag containing shelf support clips are packed inside the unit. Refer to Table 1 to verify quantity of shelves and shelf supporting clips. Bottom shelf must be placed on interior floor and should be inserted into the two retainer clips provided at the rear corners or the unit floor.

⚠ WARNING

Improper shelf clip installation may cause shelf and/or product to fall which could result in personal injury or damage to the unit.

⚠ WARNING

Do not overload the shelves. The unit is designed to use all the shelves provided, installed in equally spaced configuration. Failure to install shelves correctly could result in personal injury or damage to the unit. If fewer shelves or a different installation configuration is desired, contact the manufacturer to ensure that shelf overloading will no occur.

■ TO INSTALL SHELVES

1. Determine proper location for shelf clips. Refer to the numbers on the pilaster to ensure that all clips are properly located.
2. Insert top tab of the shelf clip into the desired hole of the pilaster. The retaining tab should be facing upward as shown in Figure 4.
3. Rotate the clip downward and insert the bottom tab into the appropriate hole on the pilaster. If necessary, squeeze the clip slightly during installation.
4. Install all remaining clips as described above.
5. Install shelves onto clips so that the product retention bar is facing upward. Be careful not to dislodge clips during shelf installation.
6. Shelves must be placed so that the retaining tab on the shelf captures the shelf as shown in Figure 5.
7. Before loading the shelf, ensure that the shelf is resting on each of 4 clips and that the clip are installed as shown in Figures 4 and 5.

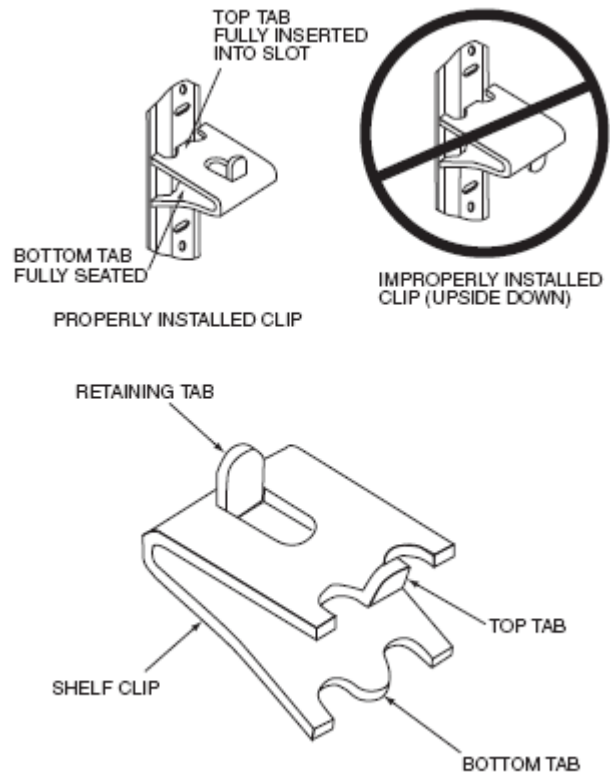

FIGURE 4 – SHELF CLIP INSTALLATION

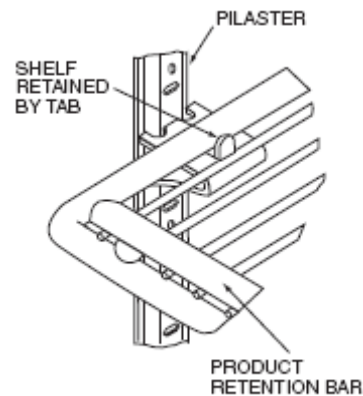

FIGURE 5 – PROPER INSTALLATION OF SHELF ON CLIP

CONDENSATE DISPOSAL

The evaporator drain pan is located in the base of the product. Airflow in compartment hastens condensate evaporation so that external drain plumbing is not required.

START-UP

PRELIMINARY CHECKS

■ BI-PIN FLUORESCENT LAMP INSTALLATION / VERIFICATION

Before applying power to the unit, verify that all lamps have been properly installed and are fully engaged in the lamp holders. There are 2 lamps in the signboard and 2 inside the cooler.

⚠ CAUTION

Improperly installed lamps may cause damage to the lighting circuit. Carrier will not be responsible for equipment or component failures or other damages or losses that arise as a result of improper lamp installation.

To achieve proper lamp engagement, rotate the lamp 90 degrees from its insertion position until it snaps or clicks into place.

On units without safety shields, visually verify proper lamp installation by checking the identification mark on the end of the bulb. If the bulb has been properly installed, the mark will be centered between the "halves" of the lamp holder. Refer to Figure 6.

On units with safety shields, the identification mark cannot be seen (See Figure 7). Verify manually that the lamp has been rotated and locked into place.

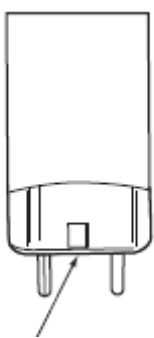

BI-PIN LAMP END IDENTIFICATION MARK

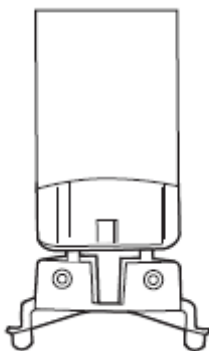

Properly installed lamp without shield. Verify identification mark is positioned as shown.

FIGURE 6 – CHECK INSTALLATION OF LAMP WITHOUT SAFETY SHIELD.

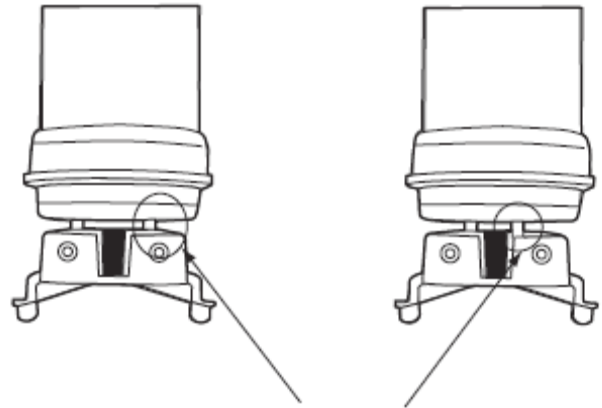

PINS MAY NOT BE VISIBLE IN ACTUAL INSTALLATION

Properly installed lamp with shield. Requires manual verification that lamp has been rotated and locked into place.

Improperly installed lamp with shield. Note that pins have not achieved full 90° rotation.

FIGURE 7- CHECK INSTALLATION OF LAMP WITH SHIELD.

■ ELECTRICAL SUPPLY AND CONNECTIONS

Check to be sure that the electrical service to the unit meets all local and national electrical codes. Unit electrical data is shown in the unit data label, located on the inside of the cabinet in the upper lefthand corner.

Review this label before initiating electrical service. Voltage range of power supply to unit should be 105 to 125 volts. Refer to Table 2 for unit data.

NOTE: Other motors or heavy appliances should not be used on the same circuit with the cooler. See Figure 1 for location of service cord.

⚠ DANGER

Before servicing unit, disconnect electrical service. Failure to disconnect electrical service could result in electrical shock and cause personal injury or death.

⚠ CAUTION

If an extension cord is necessary, use only three wire grounding type. The use of ungrounded cords or overloaded circuit voids compressor warranty.

TABLE 2 – UNIT DATA

UNIT	MC2000H / MC2000S
Voltage (V) Nominal Range	115 105-125
Frequency (Hz)	60
Total Amps	11.3
Refrigerant Type Charge Amount (oz)	R-134A 19.4
Design Pressure (psig) High Side Low Side	220 88

INITIAL START-UP

■ POWER SUPPLY

Connect unit to power supply. Check to verify that the compressor, lamp and fans are running.

Important: Low line voltage is often the cause of service complaints. Check to see that the line voltage is within specified range with the unit running.

■ TEMPERATURE CONTROL

The temperature control knob is located inside the cabinet in the motors panel. See Figure 8. Unit is factory set at the number 4 position (normal), which will maintain the product at approximately 38F. For colder temperature, turn the black adjustment knob to a higher setting. Adjust temperature control in small increments, one position at a time.

⚠ CAUTION

Allow 24 hours between temperature control adjustments. Excessive tampering with temperature control could lead to service difficulties.

NOTE: For operation above 3,000-ft altitude, thermostat should be adjusted by a qualified service technician.

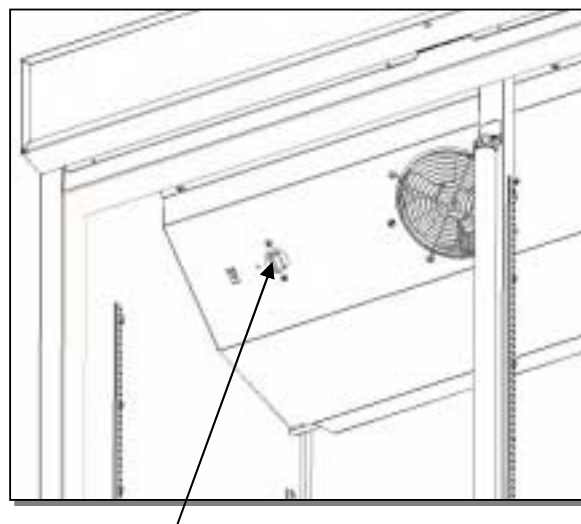

TEMPERATURE
CONTROL KNOB

FIGURE 8 – TEMPERATURE CONTROL KNOB

REFRIGERATION SYSTEM SERVICE

COMPONENTS

The Carrier Miracool™ refrigeration system consists of a hermetically sealed compressor and finned evaporator and condenser coils.

■ CONDENSER

The condenser has wide finned spaces, which allow more air passage with less dirt or dust accumulation. The condenser still requires periodic cleaning for maximum efficiency.

■ CONDENSER FAN MOTOR

The condenser fan motor assembly is mounted between the condenser and the compressor. Air is drawn through the condenser, over the body of the compressor and out the rear of the unit compartment. The motor is wired to cycle with the compressor but will continue to operate should the compressor cut out on the overload. (The motor is permanently lubricated; therefore, oiling is not required.)

■ DRIER

The drier is installed in the system just before the capillary tube. The drier traps minute particles of foreign material and absorbs any moisture in the system.

■ LIQUID CONTROL AND HEAT EXCHANGER

Liquid refrigerant control to the evaporator of the system is accomplished by the use of a capillary tube. This capillary tube is soldered to the suction line to form a heat exchanger, which subcools the liquid refrigerant to maintain high efficiency within the system.

SERVICE AND TROUBLESHOOTING

■ CONDENSING UNIT SERVICING

⚠ DANGER

Before servicing unit, disconnect electrical service. Failure to disconnect electrical service could result in electrical shock and cause personal injury or death.

1. After disconnecting the unit from the power supply, remove the grille retaining screw located in the upper-most part of the grille. (See Figure 2)
2. Lift the grille up and away from the unit.
3. Unplug the power supply cord located at the bottom of the cabinet. (See Figure 3)
4. Remove the 2 hex-head screws that hold the condensing unit base to the cabinet main rails. (See figure 9)
5. Push the condensing unit base to gain access to the refrigeration system components.

⚠ DANGER

Before servicing unit, disconnect electrical service. Failure to disconnect electrical service could result in electrical shock and cause personal injury or death.

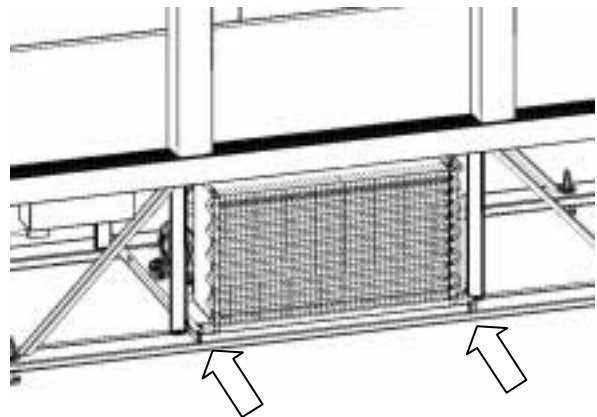

FIGURE 9 – RELEASE COND. UNIT BASE

■ EVAPORATOR COMPARTMENT SERVICING

⚠ DANGER

Before servicing unit, disconnect electrical service. Failure to disconnect electrical service could result in electrical shock and cause personal injury or death.

1. After disconnecting the unit from the power supply, remove the grille retaining screw located in the upper-most part of the grille. (See Figure 2)
2. Lift the grille up and away from the unit.
3. Unplug the power supply cord located at the bottom of the cabinet. (See Figure 3)
4. Remove the 4 philips screws that hold the evaporator cover. (See Figure 10)
5. Hold the cover until it is completely loose and hanged by the supporting pins. (See Figure 11).

⚠ DANGER

Before servicing unit, disconnect electrical service. Failure to disconnect electrical service could result in electrical shock and cause personal injury or death.

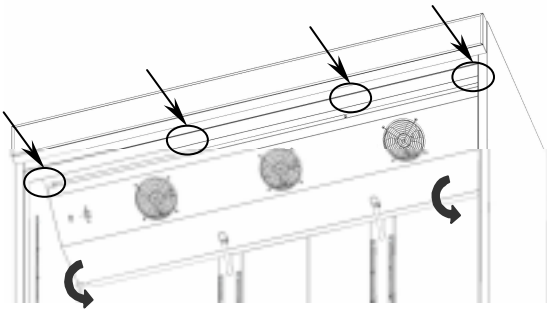

FIGURE 10 – RELEASE EVAPORATOR COVER

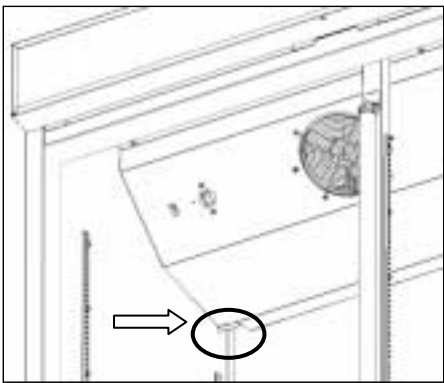

FIGURE 11 – EVAPORATOR COVER SUPPORT

■ EVACUATION

Moisture in a refrigeration system may affect performance.

When large amounts of moisture are present, system freeze ups will occur. Even in minute amounts, moisture will combine with refrigerants to form an acid.

The corrosive action of this acid forms sludge, which will plug the lines and drier.

Since most field type vacuum pumps cannot pull a low enough vacuum to remove all moisture from the system, it is recommended that the system be triple evacuated, breaking each time with dry refrigerant nitrogen. Use care to purge air from the charging hose when breaking the vacuum.

■ CHARGING REFRIGERATION SYSTEM

Refer to Table 2 for refrigerant type and amount of charge. Since capillary tube systems have small critical refrigerant charges, it is recommended that a field charge either be weighed in or transferred from a portable charging cylinder. After maximum vacuum has been obtained as detailed above, attach charging cylinder to the system line making sure to purge air from hose with refrigerant. With the unit running, allow refrigerant to run slowly into the system until the desired charge is reached. When using refrigerant blends it is recommended to charge into the high side of the system with the initial charge and then add any remaining charge into the suction side; however, care must be taken to meter the remaining amount into the low side so that excess liquid does not enter the compressor.

■ TROUBLESHOOTING

Refer to Table 3 and Figure 12.

TABLE 3 – REFRIGERATION SYSTEM SERVICE AND ANALYSIS CHART

REFRIGERATION SYSTEM		
MALFUNCTION	POSSIBLE CAUSE	SOLUTION
Compressor will not start - no hum -	<ol style="list-style-type: none"> 1. Line cord not plugged in. 2. Fuse removed or blown. 3. Overload protector tripped. 4. Temp control stuck in open position. 5. Wiring improper or loose. 	<ol style="list-style-type: none"> 1. Plug in the cord. 2. Replace fuse. 3. Refer to electrical section. 4. Repair or replace temp control. 5. Check wiring against diagram.
Compressor will not start - hums but trips on overload protector.	<ol style="list-style-type: none"> 1. Low voltage to unit. 2. Relay failing to close 3. Starting capacitor defective. 4. Improperly wired. 	<ol style="list-style-type: none"> 1. Determine reason and correct. 2. Determine reason and correct, replace if necessary. 3. Determine reason and replace. 4. Check wiring against diagram.
Compressor starts but does not switch off of start winding.	<ol style="list-style-type: none"> 1. Low voltage to unit. 2. Relay failing to open. 3. Run capacitor defective. 4. Compressor mounting winding is open or shorted. 	<ol style="list-style-type: none"> 1. Determine reason and correct. 2. Determine reason and correct, replace if necessary. 3. Determine reason and replace. 4. Determine cause, correct, and replace compressor.
Compressor starts and runs, but short cycles on overload protector.	<ol style="list-style-type: none"> 1. Additional current passing through overload protector. 2. Low voltage to unit. 3. Overload protector defective. 4. Run capacitor defective. 5. Excessive discharge pressure. 6. Compressor too hot - return gas hot. 	<ol style="list-style-type: none"> 1. Check wiring diagram. Check for added fan motors, pumps, etc. connected to wrong side of protector. 2. Determine reason and correct. 3. Check current, replace protector. 4. Determine reason and replace. 5. Check ventilation, restrictions in cooling medium, restrictions in refrigeration system. 6. Check refrigerant charge (fix leak if necessary). Check airflow across condenser.
Unit runs OK, but short cycles.	<ol style="list-style-type: none"> 1. Overload protector. 2. Cold control. 3. Overcharge. 4. Air in system. 5. Undercharge. 	<ol style="list-style-type: none"> 1. Check wiring diagram for correct wiring. 2. Differential set too close. 3. Reduce refrigerant charge. 4. Recover and recharge. 5. Fix leak and recharge with refrigerant.
Unit operates long or continuously.	<ol style="list-style-type: none"> 1. Dirty condenser. 2. Shortage of refrigerant. 3. Temperature control contacts stuck or frozen. 4. Evaporator coil iced. 5. Restriction in refrigeration system. 	<ol style="list-style-type: none"> 1. Clean condenser. 2. Fix leak, add charge, correct charge. 3. Replace temperature control. 4. Defrost. 5. Determine location and remove.
Start capacitor open, shorted or blown.	<ol style="list-style-type: none"> 1. Relay contacts not opening properly. 2. Low voltage to unit. 3. Improper relay. 	<ol style="list-style-type: none"> 1. Replace relay. 2. Determine reason and correct. 3. Replace.
Run capacitor open, shorted or blown	<ol style="list-style-type: none"> 1. Improper capacitor. 2. Excessively high line voltage (110% of rated max). 	<ol style="list-style-type: none"> 1. Determine correct size and replace. 2. Determine reason and correct.
Relay defective or burned out	<ol style="list-style-type: none"> 1. Incorrect relay. 2. Line voltage too high or too low. 3. Relay being influenced by loose vibrating mounting. 	<ol style="list-style-type: none"> 1. Check and replace. 2. Determine reason and replace. 3. Remount rigidly.
Space temperature too high	<ol style="list-style-type: none"> 1. Control setting too high. 2. Overcharged with refrigerant. 3. Inadequate air circulation. 	<ol style="list-style-type: none"> 1. Reset control. 2. Recover refrigerant and recharge with proper charge specified on data plate. 3. Improve air movement.
Cooler freezing beverage	<ol style="list-style-type: none"> 1. Temperature control 	<ol style="list-style-type: none"> 1. Reset control.
Unit noisy	<ol style="list-style-type: none"> 1. Loose parts or mountings. 2. Tubing rattles. 3. Bent fan blade causing vibration. 4. Fan motor bearings worn. 	<ol style="list-style-type: none"> 1. Find and tighten. 2. Reform to be free of contact. 3. Replace blade. 4. Replace motor.

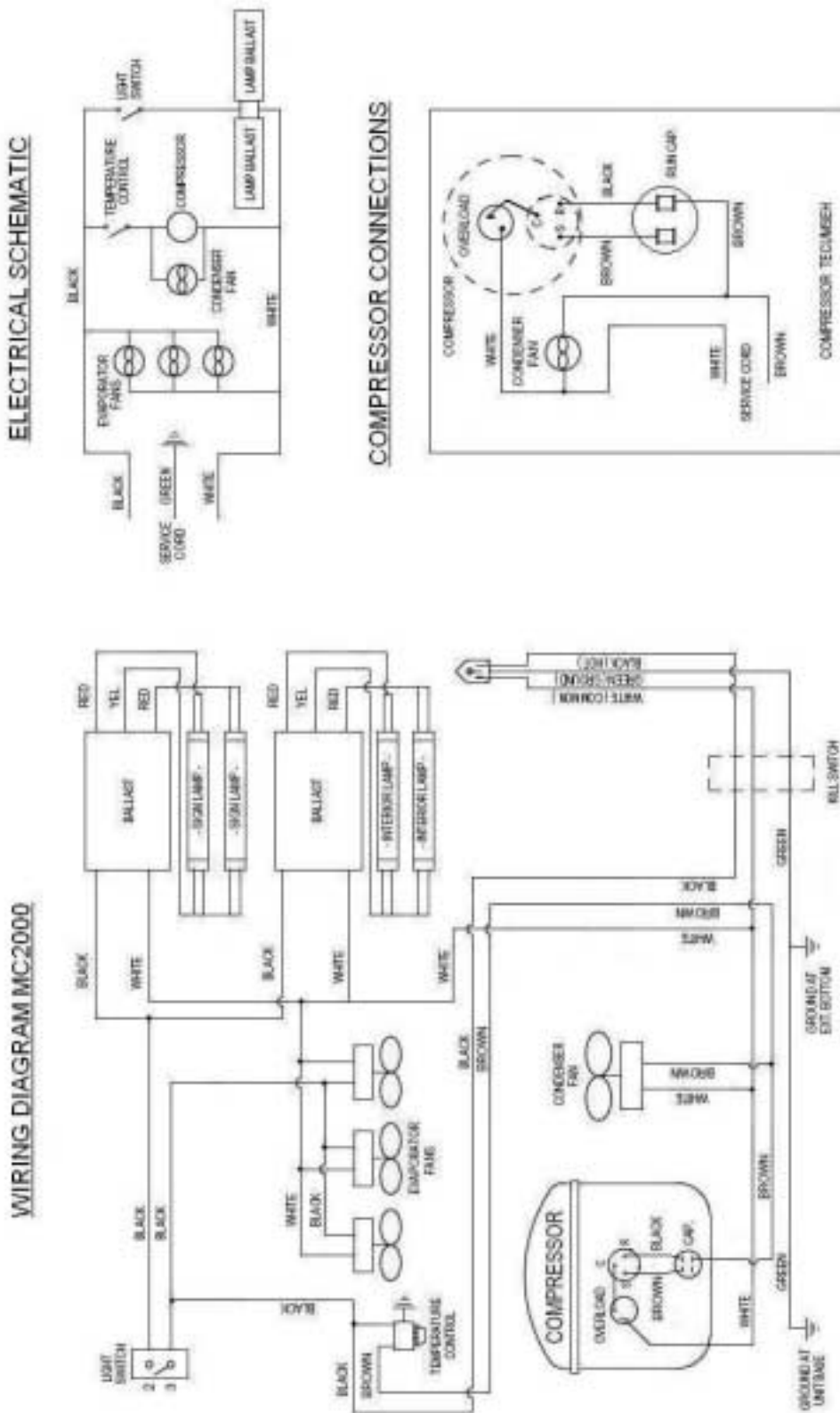

FIGURE 12 – WIRING DIAGRAM

MAINTENANCE

LAMP REPLACEMENT

⚠ DANGER

Before servicing unit, disconnect electrical service. Failure to disconnect electrical service could result in electrical shock and cause personal injury or death.

Remove lamp by rotating lamp 90 degrees to align lamp pins with holder slots. Refer to Bi-Pin Fluorescent Lamp Installation / Verification section on page 5.

CONDENSATE REMOVAL

The evaporator drain pan is located in the base of the condensing unit. The evaporator pan should be cleaned periodically to prevent odors and maintain evaporating efficiency. The pan contains wicks to assist evaporation and should be replaced periodically.

CONDENSER

⚠ DANGER

Before servicing unit, disconnect electrical service. Failure to disconnect electrical service could result in electrical shock and cause personal injury or death.

For efficient operation, it is recommended that the condenser coil and fans be cleaned every 3 to 6 months. Remove front grille for access. Refer to Condenser Unit Servicing section on page 8.

Vacuum clean front surface of coil thoroughly or direct forced air through condenser fins. Failure to clean condenser can cause compressor malfunction and will void warranty.

CABINET EXTERIOR

Cabinets should be cleaned with a solution of mild soap and water or mild household cleaner. Do not use caustic soap or abrasive cleaners, since these might damage the cabinet finish. If stainless steel surface becomes discolored, scrub by rubbing only in direction of the finish grain. Do not use steel wool or rusting may occur. Refer to Table 4.

INTERIOR SURFACE

The inside of the cabinet is coated with baked-on epoxy. To clean, use a mild soap and water solution or mild household cleaner.

EVAPORATOR HOUSING

⚠ DANGER

Before servicing unit, disconnect electrical service. Failure to disconnect electrical service could result in electrical shock and cause personal injury or death.

Evaporator and other enclosed parts normally will not require cleaning.

In case there's some spillage refer to Evaporator Compartment Servicing section on page 9 to open the compartment.

Side walls and cover should be cleaned as described in Interior Surface section in this page.

TABLE 4 –METHODS FOR CLEANING STAINLESS STEEL

TASK	CLEANING AGENT*	METHOD OF APPLICATION†	EFFECT ON FINISH
Routine Cleaning	Soap, ammonia or detergent and water	Sponge with cloth, then rinse with clear water and wipe dry.	Satisfactory for use on all finishes.
Stubborn Spots and Stains, Caked-on Splatter, and other Light Discolorations	Revere Ware, Goddard's, Twinkle or Cameo stainless steel cleaner or Soft Scrub cleaner.	Apply with a damp sponge or cloth. Rub with a damp cloth.	Satisfactory for use on all finishes if rubbing is light. Use in direction of polish lines.
	Household cleansers, such as Old Dutch, Bon Ami, Ajax, Comet.	Rub with a damp cloth. May contain chlorine bleachers. Rinse thoroughly after use.	Use in direction of polish lines. May scratch or dull highly polished finishes.
Heat Ting or Heavy Discoloration	Revere Ware, Goddard's, Twinkle or Cameo stainless steel cleaner.	Apply with damp sponge or cloth.	Use in direction of polish lines. May scratch or dull highly polished finishes.
Caked-on Foods and Grease, Fatty Acids Milkstone (where swabbing or rubbing is not practical)	Easy-Off oven cleaner.	Apply generous coating. Allow to stand for 10 to 15 minutes. Rinse. Repeated application may be necessary.	Excellent removal. Satisfactory for use on all finishes.
Hard Water Spots and Scale	Vinegar.	Swab or wipe with cloth. Rinse with water and dry.	Satisfactory for use on all finishes.

*Use of brand names is intended only to indicate a type of cleaner and does not constitute an endorsement; nor does the omission of any brand name cleaner imply its inadequacy. Many products named are regional in distribution and can be found in local supermarkets, department and hardware stores.

†All products should be used in strict accordance with instructions on package.

NOTES:

1. Use the mildest cleaning procedure that will do the job efficiently and effectively.
2. Always rub in the direction of the polish lines for maximum effectiveness and to avoid marring the surface.
3. Use only a soft cloth, sponge, fibrous brushes, plastic or stainless steel pads for cleaning and scouring.
4. Rinse thoroughly with fresh water after every cleaning operation.
5. Always wipe dry to avoid water marks.
6. Never use common steel wood pads; these will cause rust.



